



# LEFROY BROOKS

1 BROOK HOUSE ESSEX ROAD  
HODDESDON HERTS EN11 0QS UK  
T: +44 (0)1992 708 316 F: +44 (0)1992 708 317

## MK3214SE

MACKINTOSH FLOOR STANDING LADDER TOWEL  
WARMER - SEALED ELECTRIC

### DIMENSIONAL DATA SHEET

DATE: 09/11/18

REVISION: A

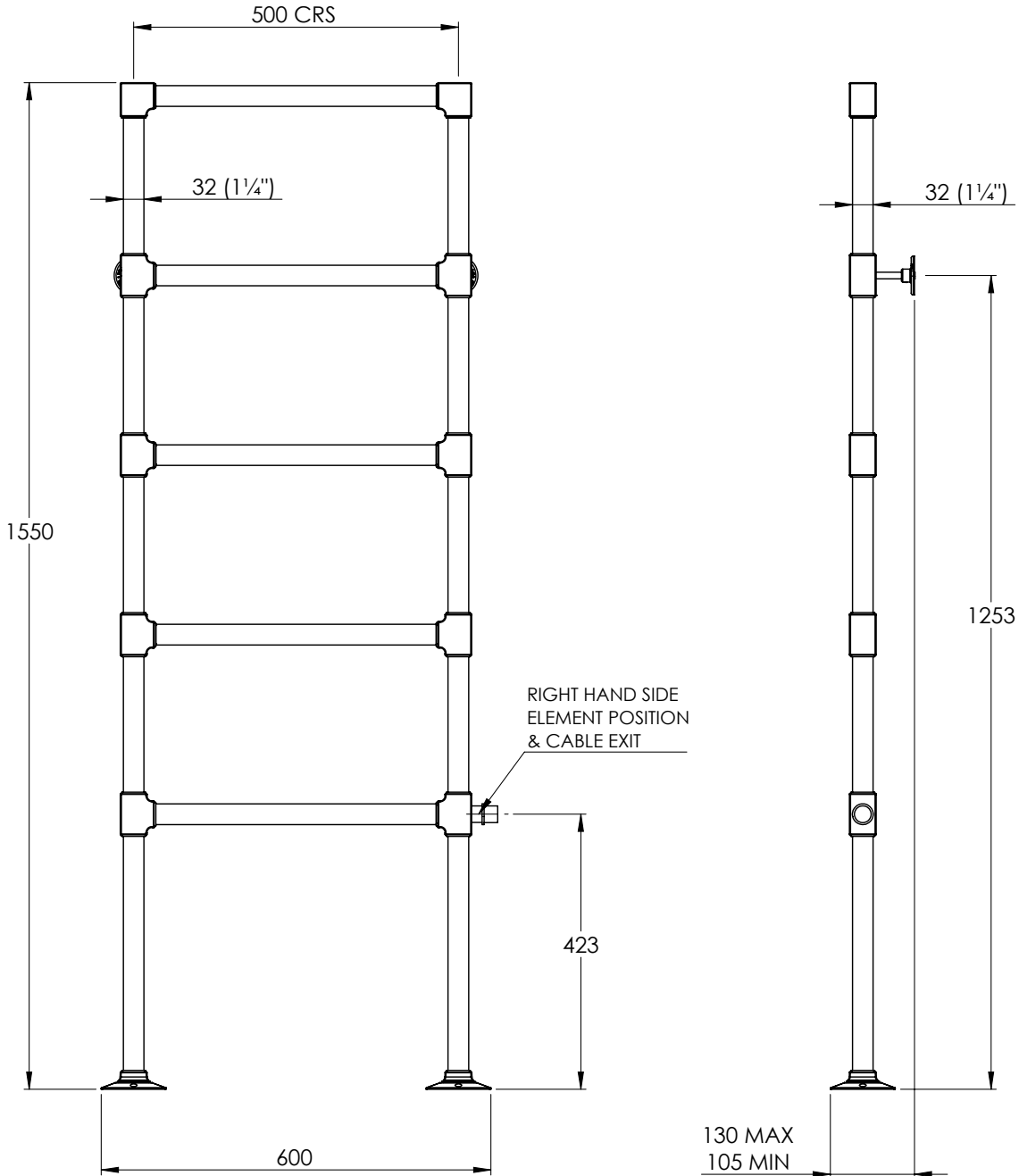

TEST PRESSURE: 6 BAR

ELECTRIC ELEMENT ( W ): 200

ELECTRICAL ELEMENT IP RATING: IPX5

DIMENSIONS IN MILLIMETRES



# LEFROY BROOKS

IBROC HOUSE ESSEX ROAD  
HODDESDON HERTS EN11 0QS UK  
T: +44 (0)1992 708 316 F: +44 (0)1992 708 317

## MK3214SE

ELECTRIC KIT

### DIMENSIONAL DATA SHEET

DATE: 09/11/18

REVISION: A

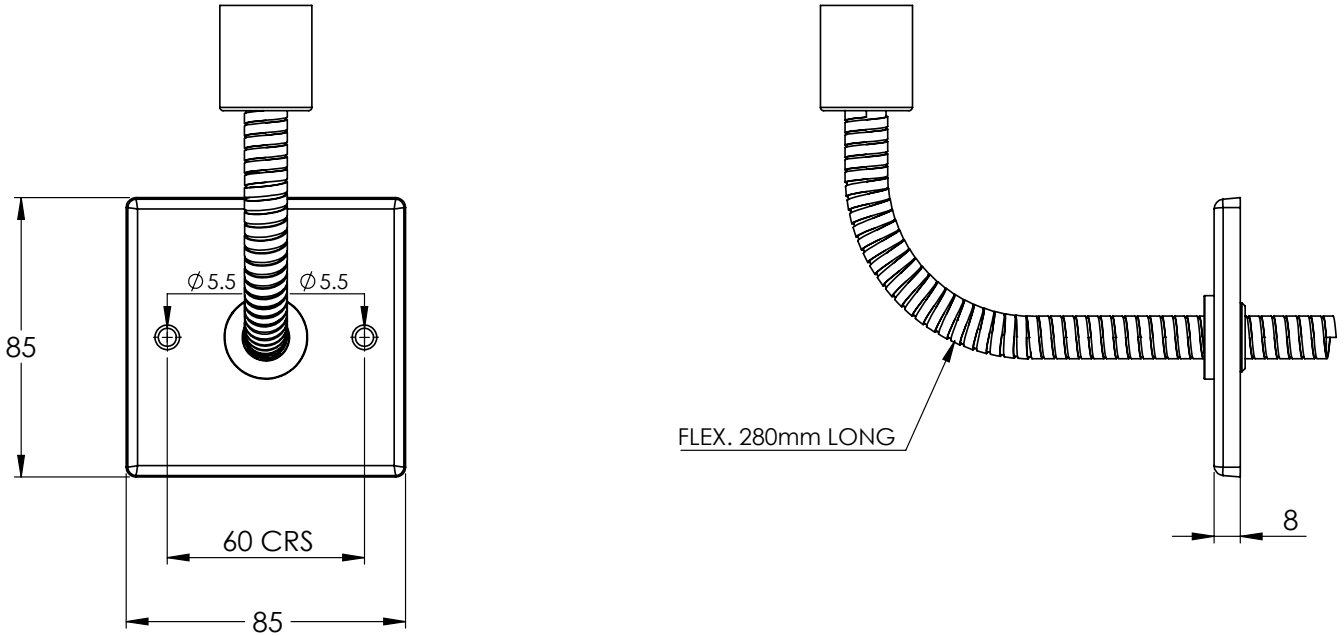

COPYRIGHT © LFB LTD. ALL RIGHTS RESERVED

DIMENSIONS IN MILLIMETRES

WHILST EVERY EFFORT IS MADE TO ENSURE THE ACCURACY OF THESE DATA SHEETS THEY ARE SUBJECT TO CHANGE WITHOUT NOTICE AS PART OF THE COMPANY'S PRODUCT DEVELOPMENT PROCESS